

W. P. HUBBARD.
WHEEL-CULTIVATOR.

No. 182,443.

Patented Sept. 19, 1876.

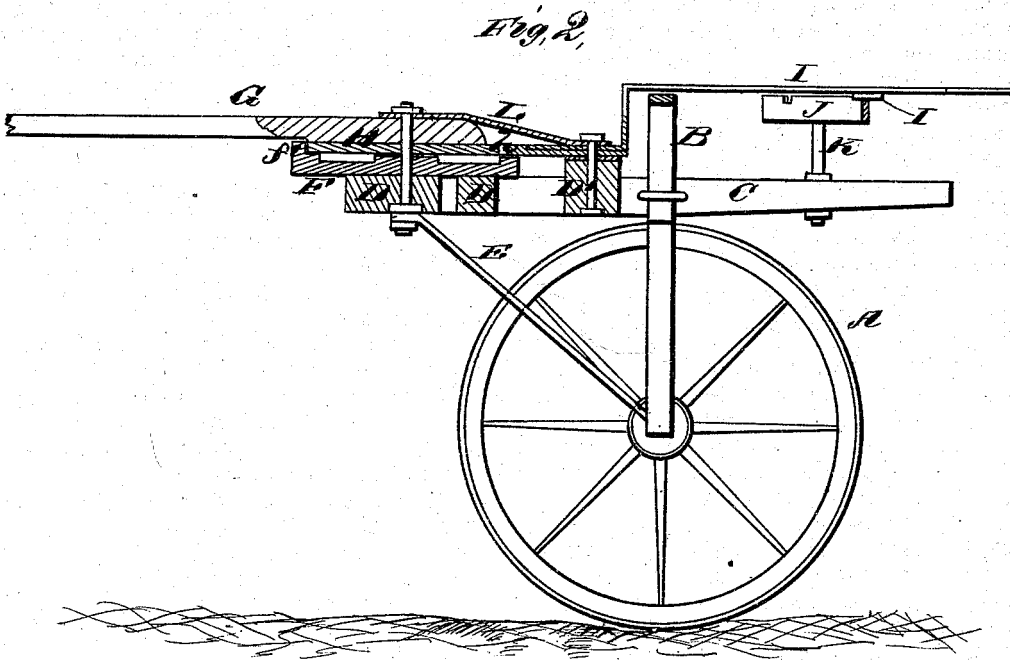
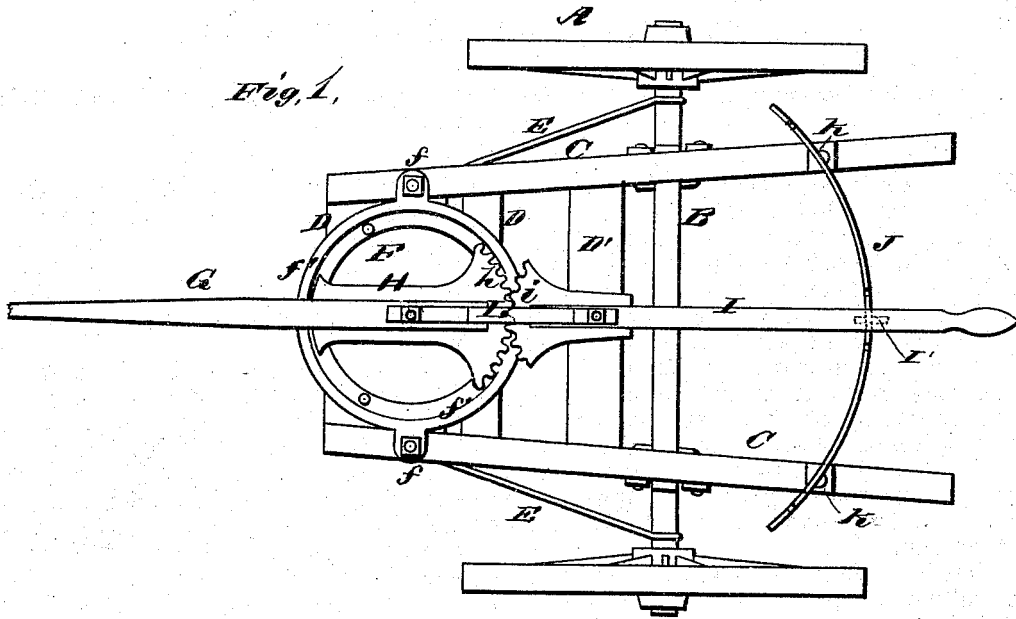

WITNESSES
H. Bates
George E. Upham.

INVENTOR.
W. P. Hubbard.
Chilmore, Smith & Co.

ATTORNEYS.

UNITED STATES PATENT OFFICE

WILLIAM P. HUBBARD, OF FARMLAND, INDIANA, ASSIGNOR OF ONE-HALF HIS RIGHT TO JOHN W. ROBINSON, OF SAME PLACE.

IMPROVEMENT IN WHEEL-CULTIVATORS.

Specification forming part of Letters Patent No. 182,443, dated September 19, 1876; application filed August 5, 1876.

To all whom it may concern:

Be it known that I, WILLIAM P. HUBBARD, of Farmland, in the county of Randolph and State of Indiana, have invented a new and valuable Improvement in Plow-Beam Adjusters; and I do hereby declare that the following is a full, clear, and exact description of the construction and operation of the same, reference being had to the annexed drawings, making a part of this specification, and to the letters and figures of reference marked thereon.

Figure 1 of the drawings is a representation of a plan view of my plow-beam adjuster; and Fig. 2 is a longitudinal vertical sectional view of the same.

This invention relates to the draft-tongues of sulky-plows and wheeled cultivators; and it consists in certain improvements therein, as will be hereinafter particularly described.

In the annexed drawing, A A designate the wheels of a sulky plow or cultivator; and B designates the arched axle connecting the same. Said axle supports longitudinal beams or side bars C C, which are connected by cross-bars D D', so as to form the bottom frame of the vehicle, from which the plow-beam is suspended. E E are braces, aiding to support said frame. On the front part of said frame a circular horizontal plate, F, is secured by means of bolts passing through ears *f f* into beams C C. Said plate is provided with a raised flange or rim, *f'*, and is constructed like the lower plate of an ordinary fifth-wheel. G is a draft-tongue of ordinary construction, pivoted to cross-bar D by its rear end, so as to be capable of lateral motion, and having rigidly secured to it a plate, H, which turns on plate F, like the upper plate of a fifth-wheel. The front of plate H is curved to correspond with the inner face of flange *f'*; but its rear is provided with segmental gear *h*, which meshes into a similar segment, *i*, that is pivoted on cross-bar D', and is rigidly secured to rearwardly-extending lever I. J is a notched segmental band, which receives a tooth, *I'*, on the under side of lever I, and locks said lever in the position to which it is turned until said tooth is raised out of the notch into which it has been placed. Said lever is constructed of elastic material, so as to have sufficient downward spring-pressure to keep said tooth in the notch until it is forcibly raised. A separate spring or weight may, however, be employed instead.

Notched band J is secured above side bars C C by means of screw-threaded supports K K, which pass upward through the same, and are vertically adjustable with relation thereto. L is a metal strap or link, which connects the pivots of draft-tongue G and adjusting-lever I.

The operation of the device is as follows: On approaching a stump or other obstacle adjusting-lever I is turned to one side, throwing draft-tongue G to the other. The plow will then pass close by said obstacle, without deviating from its line, (supposing said obstacle to lie a little on one side of the line marked out for the furrow,) while the draft-animals will be turned on one side of the same, so as not to be incommoded by said obstacle. It is equally applicable to cultivators; and will be found especially useful in turning at the end of a row, as it enables the draft-animals to turn gradually, and, at the same time, keeps the instrument operating in a perfectly-straight line until the end is reached.

This invention may be applied to vehicles of all sorts, wherever it is desirable to vary the angle of the draft-pole with the body of the wagon.

Various modifications may be made without departing from the spirit of my invention. For instance, segmental gear *h* may be secured directly to the rear end of the draft-tongue without the rest of plate H. Plate F may be dispensed with.

A rack with raised teeth may be substituted for notched band J, and numerous other changes might be suggested; but I prefer the arrangement described and shown.

What I claim as new, and desire to secure by Letters Patent, is—

The combination of the pivoted tongue G, having the toothed segment-plate H, the circular bed-plate F, the lever I, provided with toothed plate *i*, and rack-bar J, whereby the tongue is deflected and retained at any desired angle, substantially as described and shown.

In testimony that I claim the above I have hereunto subscribed my name in the presence of two witnesses.

WM. P. HUBBARD.

Witnesses:
JOHN STEWART,
W. C. SHAW.